

Introduction

Glue laminated timber members can be used successfully in weather exposed conditions.

Providing the correct species/adhesive combinations are specified, and suitable protective design and maintenance measures are implemented, glue laminated timber members will have an adequate service life in Service Class 3 (exterior exposed) applications.

This data sheet provides the specification, design and maintenance criteria which will enhance the appearance and service life of timber laminated members in weather exposed situations.

Service Class 3

AS 1328-1995 Glue Laminated Structural Timber defines three service classes - 1, 2 and 3.

Service Class 3 encompasses those situations where the equilibrium moisture content of the timber will, periodically, exceed 20% and the member is fully exposed to the elements.

Where laminated timber members are used in exposed situations, it is vital that the correct species/adhesive combination is specified and that appropriate protective measures are taken to preclude the adverse effects of ultra violet light and moisture ingress to the timber.

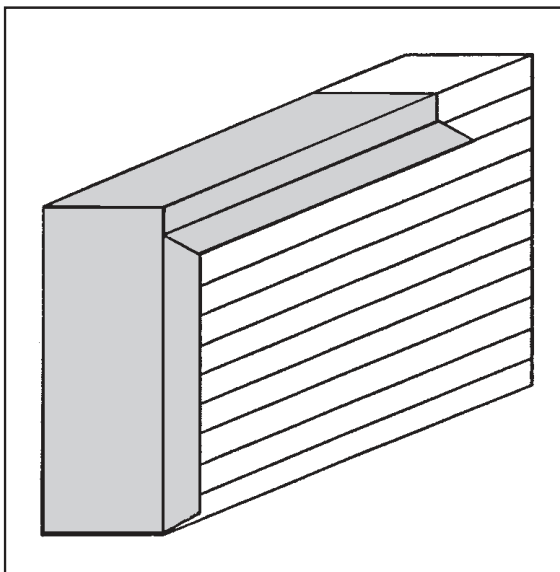

Diagram No. 1 - Illustration of Typical End

Product Specifications

The two factors affecting the inherent durability of laminated timber beams in exposed situations are:

- (a) Species
- (b) Adhesive Type

(a) Species

The species of hardwood timber used in laminated beams destined for Service Class 3 applications should be durability Class 1 or 2. AS 1720.1-1988 provides the durability rating of most commercial timber species used in Australia.

Most softwood species can be treated with non-leachable preservative salts (CCA) which will impart decay resistance. The level of CCA preservative treatment specified for softwood laminated beams used in Service Class 3 applications should be H3. Similarly LOSP envelope treatment can be used satisfactorily. Check with manufacturer for recommended use.

(b) Adhesive Type

Adhesives used to bond laminate together for Service Class 3 applications should be of the Polyphenolic/Resorcinol type.

Protective Measures

In exposed service situations, UV light will break down lignin in the timber, which bonds wood fibre together, and moisture ingress to the timber will cause dimensional instability and promote fungal decay (rot).

A number of issues must be addressed to limit the adverse effects of ultra violet light and moisture on timber laminated beams. These are:

- (a) Design Best Practice
- (b) Protective Coatings
- (c) Maintenance

(a) Design Best Practice

The design of structures incorporating timber laminated members which will be fully exposed to the elements should include measures to mitigate exposure to direct sunlight and moisture ponding, and promote rapid shedding of moisture.

The following detailing and design practices are desirable with regard to enhancing the structure's service life:

- (i) Joint detailing should comply with the following:
 - ensure moisture entering the joint is not trapped but can run away freely
 - keep horizontal contact areas to a minimum, favouring self-draining vertical surfaces

GLUE LAMINATED BEAMS IN EXPOSED SITUATIONS continued

- keep horizontal contact areas to a minimum, favouring self-draining vertical surfaces
- use non-corroding fasteners which do not cause splitting during installation
- minimise use of morticed joints.

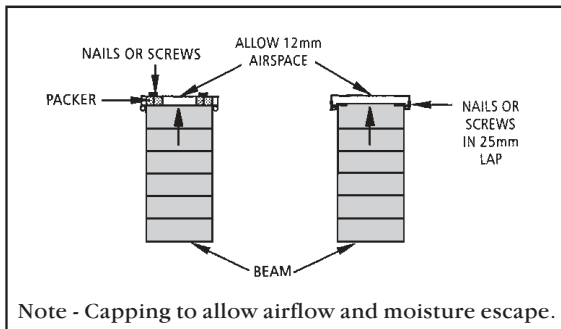

Note - Capping to allow airflow and moisture escape.

Diagram No. 2 - Capping Details

- (ii) Beams should be provided with adequate ventilation.
- (iii) Damp proof membranes should be used where timber members are in contact with masonry.
- (iv) Metal or plastic shields on the top and ends of laminated timber beams can exclude moisture and sunlight.
 Refer to diagram 1 and 2.
- (v) Arrissed edges on timber members help prevent the failure of coating systems.
- (vi) Building overhangs will provide protection from moisture and direct sunlight.

(b) Protective Coatings

Protective finishes will prolong the service life of structures incorporating laminated timber members by excluding UV light and moisture ingress and imparting dimensional stability to the timber members.

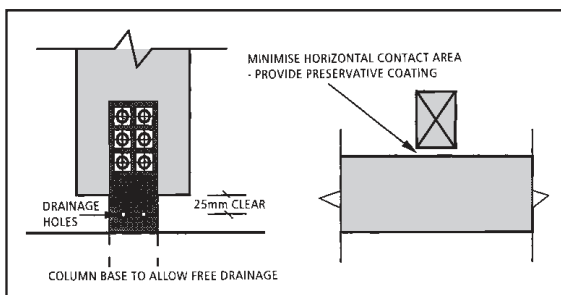

Diagram No. 3 - Detailing to avoid moisture traps

The following products are available:

- (i) Oil based surface applied preservatives, in brushing and paste forms, impart fungal resistance and dimensional stability in the short term. They should be used to provide protection to laminated members from the elements during construction. Their compatibility with finishes intended for the long term protection of the members should be confirmed prior to use.
- (ii) Oil based stains are non-film forming and penetrate the timber to provide weathering resistance while leaving the grain semi-exposed. This protective coating should be renewed annually if adequate protection is to be achieved.
- (iii) Oil based paint systems will provide the best long term protection of laminated members in Service Class 3 conditions. Paint manufacturers' instructions should be followed, but will usually consist of the following:
 - 1 coat of oil based primer
 - 1 coat of oil based under coat
 - 2 coats of oil based exterior house paint.
- (iv) Acrylic paint systems are popular. When combined with oil based primers and recoated every five years they will provide satisfactory protection.
- (v) Clear finishes are not recommended for timber used in exposed applications due to an absence in UV filters and a propensity to break down readily in exposed situations.

In selecting a finish for laminated timber members in Service Class 3 conditions, consideration must be given to the need to effectively and permanently remove the effects of UV light and moisture ingress to the member.

Special attention should be given to sealing exposed end grain at the end of members and joints.

(c) Maintenance

Timber laminated members in exposed applications will give excellent service life if the protective design and coating measures are maintained to limit the effect of weathering. A maintenance schedule should be documented and implemented for all structures. Coatings should be renewed in accordance with manufacturers' instructions and joint and capping details kept in good repair.